

# OPERATING AND INSTALLATION INSTRUCTIONS

DHW HEAT PUMPS

- » WWK 300 A
- » WWK 300 AP
- » WWK 300 AH
- » WWK 300 AHP

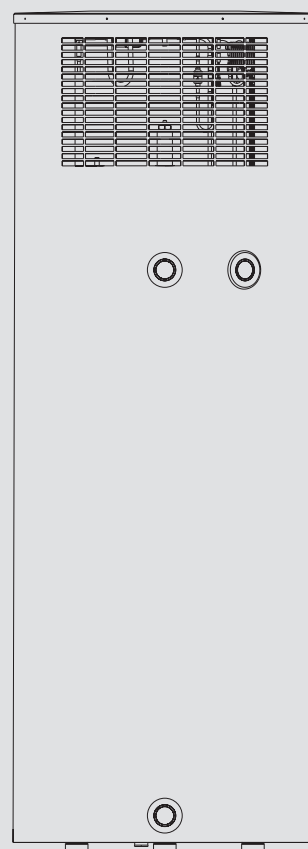

**STIEBEL ELTRON**

## Contents

<b>1. Operating instructions for users and contractors</b>	<b>3</b>
1.1 Operation and control	3
1.2 Device description	3
1.3 Correct operation	3
1.4 Incorrect operation	3
1.5 Function description	3
1.6 Operation with active defrost feature WWK 300 A and WWK 300 AH	3
1.7 Operation with passive defrost feature WWK 300 AP and WWK 300 AHP	3
1.8 Maintenance and cleaning	3
1.9 Troubleshooting by the user	4
<b>2. Installation instructions for contractors</b>	<b>5</b>
2.1 Regulations and standards	5
2.2 Installation	6
2.3 Water connection	6
2.4 Power supply	7
2.5 Commissioning	8
2.6 Safety equipment and maintenance	8
2.7 Specification	14
<b>Warranty</b>	<b>15</b>
<b>Environment and Recycling</b>	<b>15</b>

### Symbols used in these instructions

Observe the following safety instructions:



Please note: Warning about possible dangers.



Note: Important information and tips.



Note: Carefully read these operating and installation instructions and keep them safe. Should the equipment change hands, pass these instructions to the subsequent owner. Pass them to the trained contractors for servicing purposes.

Positioning, installation and commissioning must be carried out by trained personnel working in accordance with these **operating and installation instructions**.

Where children or persons with limited physical, sensory or mental capabilities are to be allowed to control this equipment ensure that this will only happen under supervision or after appropriate instructions by a person responsible for their safety. Children should be supervised to ensure that they do not play with the equipment.



## 1. Operating instructions for users and contractors

### 1.1 Operation and control

The Stiebel Eltron domestic hot water heat pump WWK 300 A/AP/AH/AHP (DHW) is a DHW generator that operates automatically and has a capacity of approx. 300 L. The water temperature is permanently set to 60 °C.

The device is installed, connected and handed over ready for use by a qualified contractor. Nevertheless, you should familiarise yourself with the most important technical features of your heat pump.

### 1.2 Device description

The device extracts heat from the ambient air.

This energy is used to heat the water inside the cylinder. Where the device is installed inside a room, this is cooled down through the heat extraction by approx. 1 to 3 °C. The device also extracts moisture from the ambient air that creates condensate, which must be drained off. For this purpose, a condensate drain with closure incl. a strainer is integrated in the floor of the device.

#### Special features of the WWK 300 AH and WWK 300 AHP

An electric booster heater is integrated for heating approx. 100 litres of water in the upper sector of the DHW cylinder.

### 1.3 Correct operation

The DHW heat pump is designed for extracting heat from the ambient air and the utilisation of that energy for heating domestic hot water. The DHW heat pump can be installed in the open as well as in enclosed spaces.

### 1.4 Incorrect operation

The following are not permitted:

- The utilisation of greasy extract air.
- The heating of liquids other than domestic hot water.
- The installation of the equipment:
  - a) in rooms where the temperature is below the freezing point.
  - b) in rooms where the device is at risk from explosions as a result of dust, gases or vapours.
- Operation of the device with an empty cylinder.

### 1.5 Function description

#### Heat pump operation

This is the standard operating mode, to which the limits of scope of the heat pump apply (see: Specification). To heat up the cylinder capacity of approx. 300 litres of water in accordance with EN 255 part 3 to 60 °C, the WWK 300 requires ... :

$\tau_{\text{Heat-up}}$	$\vartheta_{\text{Room}}$	$F_{\text{rel}}$	$\vartheta_{\text{Cold water}}$	COP (t)
10.1 h	15 °C	70 %	15 °C	3.19
5 h	42 °C	70 %	15 °C	5.61

If the heat pump is switched OFF and ON again, for instance after a power failure, the compressor will only re-start (after approx. 3 minutes), when the pressure inside the refrigerant circuit has normalised again.

#### Electric booster heater (only for the WWK 300 AH and WWK 300 AHP)

If there is a higher DHW demand or when the WWK was switched OFF and you require hot water quickly, you can accelerate the heat-up process by means of the electric booster heater. For reasons of saving energy, the electric booster heater will only heat up approx. 100 litres of water in the upper section of the cylinder.

The control thermostat of the electric booster heater is preset to 60 °C and will be restarted when the DHW temperature falls below 45 °C. This safeguards not only that primarily the heat pump provides hot water, but also that you enjoy a high level of DHW convenience when large amounts of hot water are drawn.

#### 1.6 Operation with active defrost feature WWK 300 A and WWK 300 AH

Subject to the relative humidity and the DHW temperature, the evaporator begins to build up hoar frost at an ambient temperature of below 6 °C.

If the evaporator is covered in hoar frost, the frost monitor N2 (see wiring diagram Fig. 6 and 7) switches the fan OFF, whilst the compressor continues to run, and the changeover valve V2 routes the hot gas directly to the evaporator. For this, the condenser is shut off by changeover valve V1 (see Fig. 4) When the temperature at the evaporator fins rises above 3 °C, the fan is started again, and DHW heating continues.

The DHW heat pump can be operated at ambient temperatures as low as 0 °C. The evaporator is defrosted according to demand in the temperature range 0 °C to +6 °C. This extends the heat-up time.

#### Ambient temperature

The heat pump must not be installed in areas where ambient temperatures frequently exceed 42 °C or areas where temperatures frequently drop below 0 °C

### 1.7 Operation with passive defrost feature WWK 300 AP and WWK 300 AHP

The limit of application of the WWK AP / AHP (without hot gas defrost feature) is set to 6 °C.

However, with this limit of application, the evaporator may build up hoar frost subject to air temperature and relative humidity, particularly when the DHW temperature is low. The compressor will be switched OFF as soon as the evaporation temperature lies below -7 °C for any length of time. When the temperature at the evaporator fins rises above 3 °C, the compressor are started again, and the DHW heating continues.

#### Ambient temperature

The heat pump must not be installed in areas where ambient temperatures frequently exceed 42 °C or areas where temperatures frequently drop below 6 °C

### 1.8 Maintenance and cleaning

The device is generally maintenance free, with the exception of cleaning the strainer in the condensate drain.

Sand and dust can result in sludge building up inside the strainer. Therefore, clean the strainer at least twice per annum or in accordance with demand.

A damp cloth is sufficient for cleaning all plastic parts. Never use scouring or solvent-based cleaning agents.

Please note: Maintenance work, e.g. checking the electrical safety, must only be carried out by a qualified contractor.

- Check the condensate drain at least monthly at the bottom strainer outlet and at the top condensate pan drain (visual check, see Fig. 4, pos 16).

Remove contaminants and blockages immediately.

- For the WWK300 AH and WWK300 AHP, it is recommended that the electric booster heater be descaled from time to time. This will result in prolonged life for the electric booster.
- Your local contractor, who is familiar with the local water quality, should identify for you the timing of the next service.
- Ask your local contractor to regularly check the safety assembly and the electric booster heater.
- The device is subject to mains water pressure. The expansion water drips from the safety valve during heat-up. Inform your local contractor of water drips from the system after the heat-up process has ended.
- To protect the steel cylinder against corrosion, the interior is coated with a special enamel and is furthermore equipped with a protective anode. Ask your local contractor to check the protective anode regularly.

## 1.9 Troubleshooting by the user

### No hot water

Should you fail to obtain hot water at any time, you can take the following steps to remedy that situation.

### No electrical power

Check the fuse/circuit breaker in your fuse box. If it has blown/tripped, replace/reset the fuse/MCB. If it should blow/trigger repeatedly, notify your local contractor.

### Still no hot water, even though power is available

Check, whether the air inlet/outlet is blocked.

The thermostatic switch trips out or the high limit safety pressure limiter switches the compressor OFF if the compressor is overloaded due to excessive ambient temperature or excessive air temperature (>42 °C), or because of a fault in the refrigerant circuit. Ask your local contractor to remove the fault.

The thermostatic switch automatically switches itself ON again.



**The high limit safety pressure limiter must only be reset by your contractor after he has removed the cause of the relevant fault.**

### Other issues

#### Safety valve of the cold water supply line drips

This may occur during the heat-up phase and is completely normal.

#### The condensate drain drips

This always happens when the surface temperature of the evaporator is lower than the ambient dew point temperature.

For all other faults, consult your contractor.



## 2. Installation instructions for contractors

### 2.1 Regulations and standards

- The installation (water and electrical work) and commissioning, as well as the maintenance of this equipment, must only be carried out by an authorised qualified contractor in accordance with these instructions.
- Perfect function and safe operation can only be assured when using original accessories and spare parts intended for this equipment.
- DIN VDE 0100 / DIN VDE 0701
- Regulations of your local electricity supply utility.
- DIN 1988 / DIN 4109
- Regulations of your local water supply utility.

The following standards were taken into account:

AS 4234, AS 3498, AS 4020, AS 1056.1  
 AS/NZS 2712, AS/NZS 3350.2.40/30/30.2  
 IEC 60335-1-2-40, IEC 61000-3-2; 1995  
 IEC 61000-3-3, IEC 55014-1 IEC 55014-2  
 EMC Directive 89/336/EEC  
 EN 255 T3

Also observe the following:

- The equipment type plate
- The specification
- Water installation
  - Observe the AS/NZS 3500. [local regulations].

- Material of the cold water line: Steel, copper or plastic pipe systems.
- Material of the hot water line: Copper or plastic pipe systems.

### Connection dimensions and variations

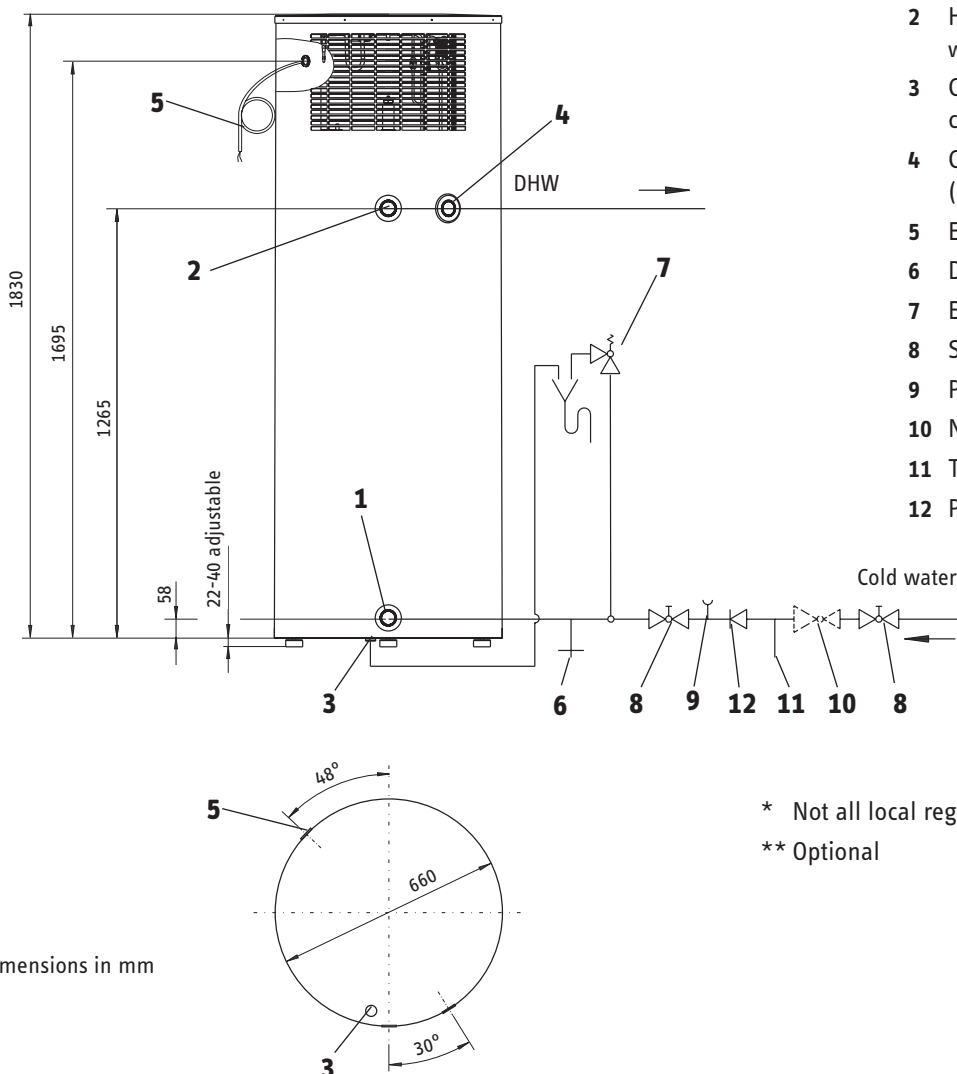

- 1 Cold water supply R 1" (3/4" femal with adapter)
- 2 Hot water connection R 1" (3/4" femal with adapter)
- 3 Condensate drain 3/4" hose connection
- 4 Connection for P&T relief valve R 3/4" (on-site)
- 5 Electrical cable
- 6 Drain valve
- 7 ECV (if required\*)
- 8 Straight-through shut-off valve
- 9 Pressure gauge test connector\*\*
- 10 Non-return valve\*\*
- 11 Test valve connection\*\*
- 12 Pressure reducing valve\*\*

\* Not all local regulations require the use of an EVC.  
 \*\* Optional

Fig. 1

## 2.2 Installation

### Transport

To protect the equipment against damage, it must be transported vertically inside its dedicated packaging. Where space is restricted, you may also move the equipment tipped backwards at an angle.

### Positioning

- Position the device in the installation location.

**Note:** Ensure that the casing panel in the lower area of the device is not damaged during positioning.

- Remove packing straps and polystyrene mouldings.
- Level the device by adjusting the equipment feet.

### External installation

The location where the WWK is to be installed must meet the following conditions:

- Load-bearing floor (wet weight of the WWK approx. 430 kg).
- Never operate the WWK in rooms at a risk from explosion due to dust, gases or vapours.

### Internal installation

The room where the WWK is to be installed must meet the following conditions:

- Load-bearing floor (wet weight of the WWK approx. 430 kg).
- Never operate the WWK in rooms at a risk from explosion due to dust, gases or vapours.
- Include in your considerations the utilisation of waste heat, for example from a boiler, tumble drier or refrigerator/freezer.
- The available floor area in the installation room must be at least 6 m<sup>2</sup>. Never install this equipment in rooms with a volume of less than 13 m<sup>3</sup>.
- Never restrict the clearances of the WWK through walls and ceilings further than illustrated in Fig. 2.
- The room temperature must never fall below 0 °C, as the ambient temperature will be reduced by approx. 1-3 °C through the heat pump operation. The initial temperature is reached again approx. ½ h after the heat pump has been switched OFF.

When installing the heat pump in a boiler room, ensure that the boiler operation will not be impaired.

### 2.3 Water connection

- Remove the protective caps from the connectors.
- With a sharp knife, cut a hole into the protective caps and invert over the pipe to be connected.
- Connect the pipe and refit the protective caps.

**Please note:** To protect against the risk of corrosion, make the connection as flat packing seal. The use of hemp on connections is not acceptable.

Insulate the DHW line in accordance with local regulations.

Accurately maintain the order of fittings on the cold water side (see Fig. 1).

Flush the line prior to installation.

Install a drain valve at the lowest point of the cold water supply line.

Install a pressure reduction valve when the water pressure is higher than 500 kPa (5 bar).

Special measures are required at a water pressure in excess of 10 bar (see DIN 1988).

### Expansion control valve (Fig. 1, pos. 7)

Observe the local requirements for an ECV (optional)

- The diameter of the connecting pipe must not be larger than the safety valve diameter.
- Size the drain so that water can drain off, even if the safety valve has been fully opened.
- The drain outlet must not be able to be closed and must always remain open to atmosphere.
- The safety valve must open at 475 kPa.

### P&T relief valve (Fig. 1, pos. 4)

Atsite: Install the provided P&T relief valve.

The P&T relief valve must open at 600 kPa.

### Condensate drain

The device is designed so that, if it is installed externally, the condensate can freely drain away. However, the condensate can also (in case of internal installation) be routed into a drain in the floor or into a wall drain connection located at a higher point.

If the condensate is to be routed through a higher wall outlet, position the heat pump on a plinth (see Fig. 2), and route a suitable drain hose on site.

**Note:** Never kink the hose, to ensure the condensate drains perfectly.

If required install a condensate pump (part no. see page 13).

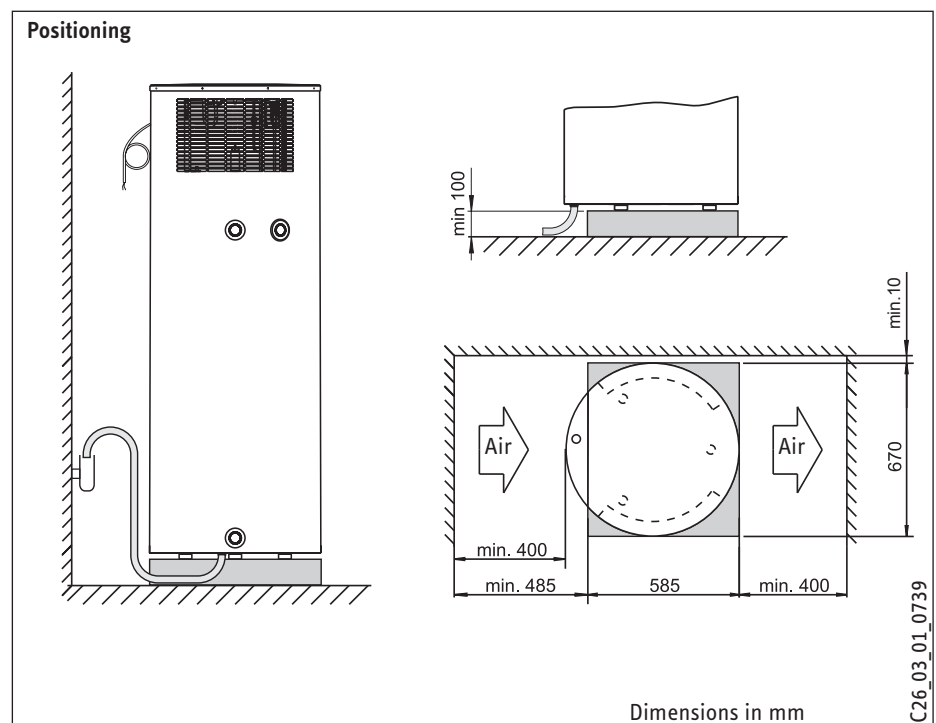

Fig. 2

## 2.4 Power supply

Only qualified electricians must carry out the installation in accordance with these instructions.

**⚠ Please note: Before any work, isolate the equipment from the power supply at the control panel.**

Observe VDE 0100 [or local regulations] and the regulations of your local power supply utility.

The appliance is intended to be permanently connected to fixed wiring. For the connection to the power supply the fitted supply cord has to be used. (Fig. 3, pos. 19)”

The DHW heat pump must be able to be separated from the mains power supply by an additional isolator, which disconnects all poles with at least 3 mm contact separation. For this purpose, use contactors, mains isolators, fuses, etc. on site.

Terminals are located inside the control panel and become accessible by removing the equipment lid and the cover of the wiring chamber (Fig. 3).

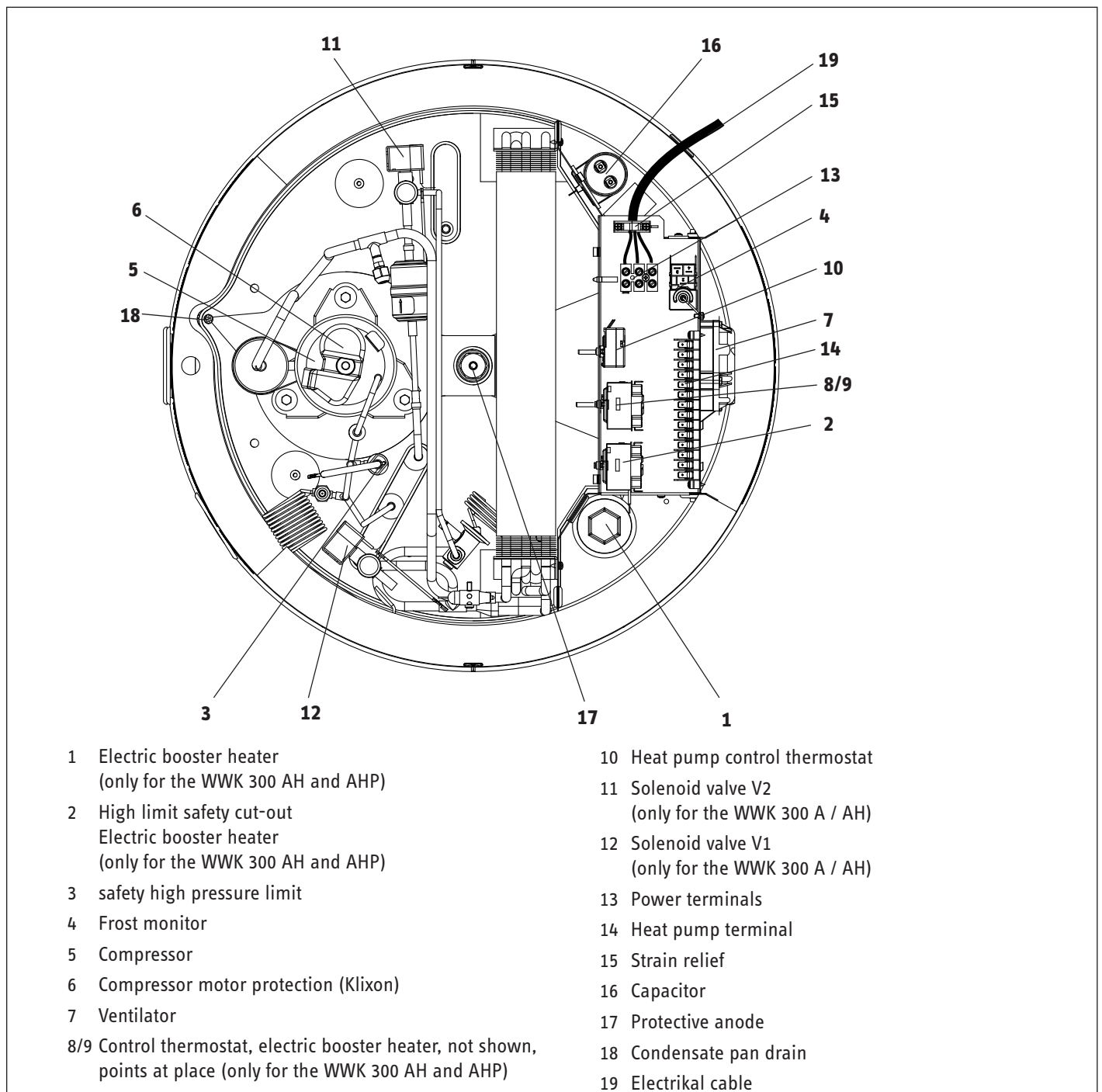

Fig. 3

## 2.5 Commissioning

Only approved contractors may commission this equipment and instruct the owner in its use.

### Commissioning

- Fill, vent and thoroughly flush the device.
- Check the safety assembly.  
Inform the user that water may drip from the safety valve whilst the water is being heated up.
- Switch ON the power supply

### Note:

- Never operate the equipment outside the temperature range 0 °C to + 42 °C.

At temperatures below - 15 °C (e.g. transport/storage), the safety temperature cut-out can respond. Press the reset button to remedy this situation (Fig. 3, pos. 3).

## 2.6 Safety equipment and maintenance

**Only qualified contractors must carry out the installation in accordance with these instructions.**

### On the equipment

In case of a fault, the safety equipment of the WWK 300 interrupts the relevant power circuit.



**Please note: Before any work on the equipment, disconnect all poles from the mains.**

### High limit safety cut-out (STB) electric booster heater

Equipment with electric booster heater is stopped if the DHW temperature exceeds 95 °C.

When the source of the fault has been removed, reset the high limit safety cut-out by pressing the reset button (pos 2, Fig. 3).

The heat pump top cover should be opened for access to this device as shown in fig. 3.

### Safety high pressure limiter (SDBK) Fig 3

The safety high pressure limiter shuts down the compressor, if the pressure inside the refrigerant circuit exceeds the

permissible maximum value. The safety high pressure limiter may also respond, if the WWK 300 is operated above its permissible limit (>45 °C air temperature) or the control thermostat of the heat pump fails to respond. Reset the high pressure limit safety cut-out by pressing the reset button (pos 3, Fig. 3), after the cause of the fault has been removed.

### Protective motor thermoswitch

The protective motor switch will shut down the compressor, if it is overloaded because of excessive thermal load. Remove the relevant fault. The protective motor switch restarts the compressor automatically after 5 - 15 seconds.

### Protective anode

An anode for the protection of the DHW cylinder is inserted right in the center of the heat pump cylinder (item 17, fig.3). Replace the anode with a new one if the installed one has been consumed. When installing the anode, ensure that the metallic conductor connection is correctly made. It's recommended for first anode inspection to happen after 2 years after installation. Your contractor, who will be familiar with your water quality, will advise you of the optimum timing for inspection thereafter. Should it be impossible to insert a rod anode, part no. 143496 from above, you may have a sectional anode installed instead.

### Cleaning the evaporator

Maintaining the full output of the WWK 300 requires an occasional professional cleaning of the evaporator. Clean the evaporator only with water and a brush. Never use acidic or alkaline cleaning solutions.

### Further information regarding the equipment:

#### ● Cleaning and descaling

After removing the plug or the electric booster heater (if installed), clean the cylinder through the inspection aperture.

Use a descaling pump to descale the cylinder. Connect the pump between the cold water connection and the inspection aperture. Ensure that the protective anode is removed prior to descaling. When installing the anode, ensure that the metallic conductor connection is correctly made.

#### ● Draining the cylinder:

- Close the shut-off valve in the cold water supply.
- Fully open the hot taps at all draw-off points.
- The cylinder is drained via the cold water inlet line. Residual water remains in the lower part of the cylinder.



**Note: Hot water can be expelled during draining.**

### On the system

#### Safety valve (on-site)

This valve opens when the water pressure exceeds the preset value of 600 kPa (6 bar) thereby relieving the pressure. It is adjusted so that no water will be expelled when heating is switched OFF. Should it continue to drip excessively, either the valve seat has become contaminated, the water pressure is too high or the pressure reducing valve has become faulty.

#### Pressure reducing valve (on-site provision)

Check the valve for perfect function. Replace it, if required.

#### Regular valve maintenance

Safety requires that valves are regularly checked for perfect function. For this, regularly vent the safety valve until a full stream of water flows from it. Close the safety valve after checking.

How quickly limescale builds up depends on the local water quality.

As your local contractor is familiar with your local water quality, let him determine the timing of this check.



# Wiring diagram WWK 300 A

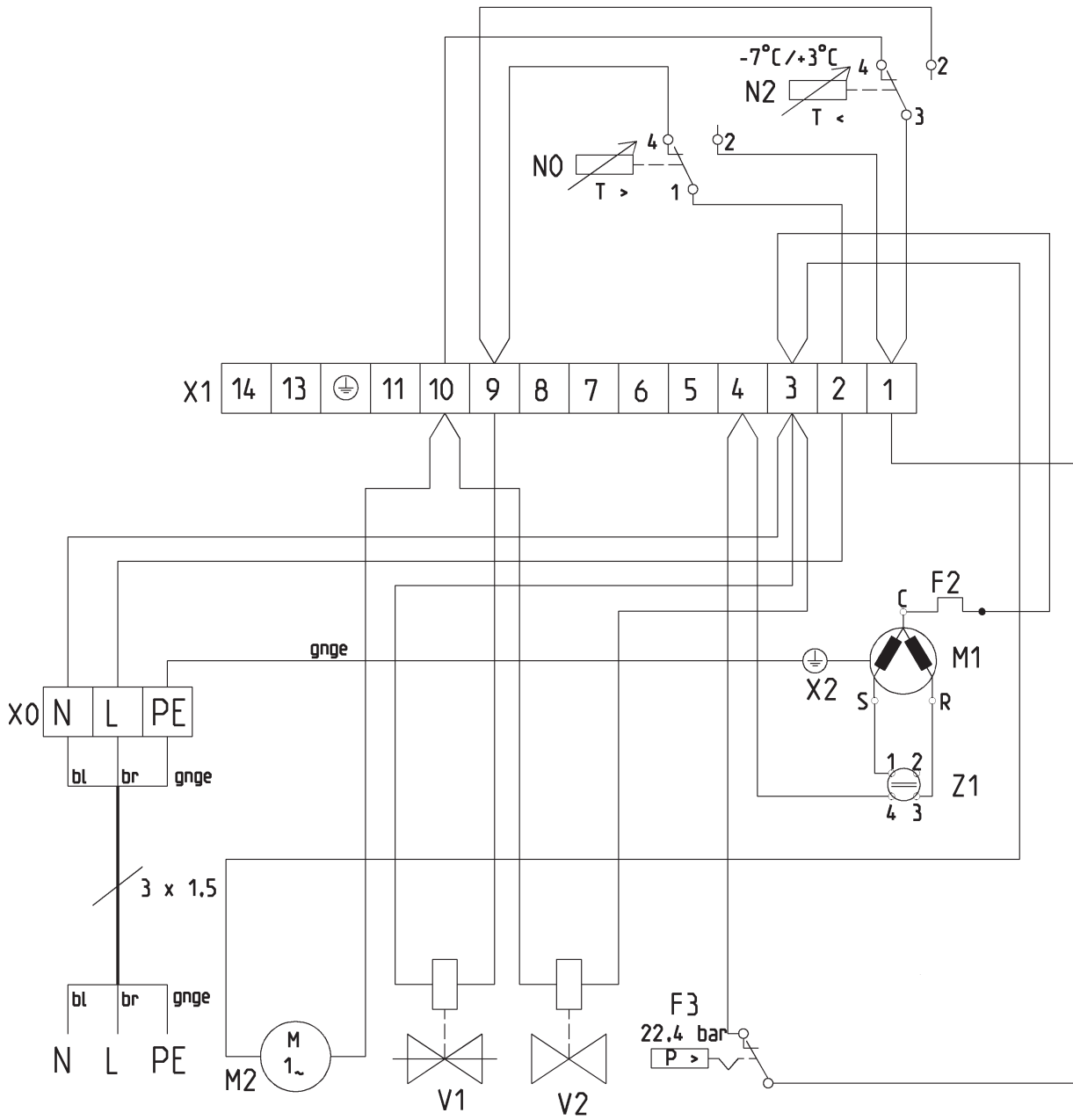

- F2 Compressor motor protection (Klixon)
- F3 High limit safety cut-out
- M1 Compressor
- M2 Fan
- N0 Heat pump control thermostat
- N2 Frost monitor
- V1 Solenoid valve
- V2 Solenoid valve
- X0 Power terminals
- X1 Heat pump terminals
- X2 Anode terminal earth
- Z1 Capacitor

Fig. 6

## Wiring diagram WWK 300 AP

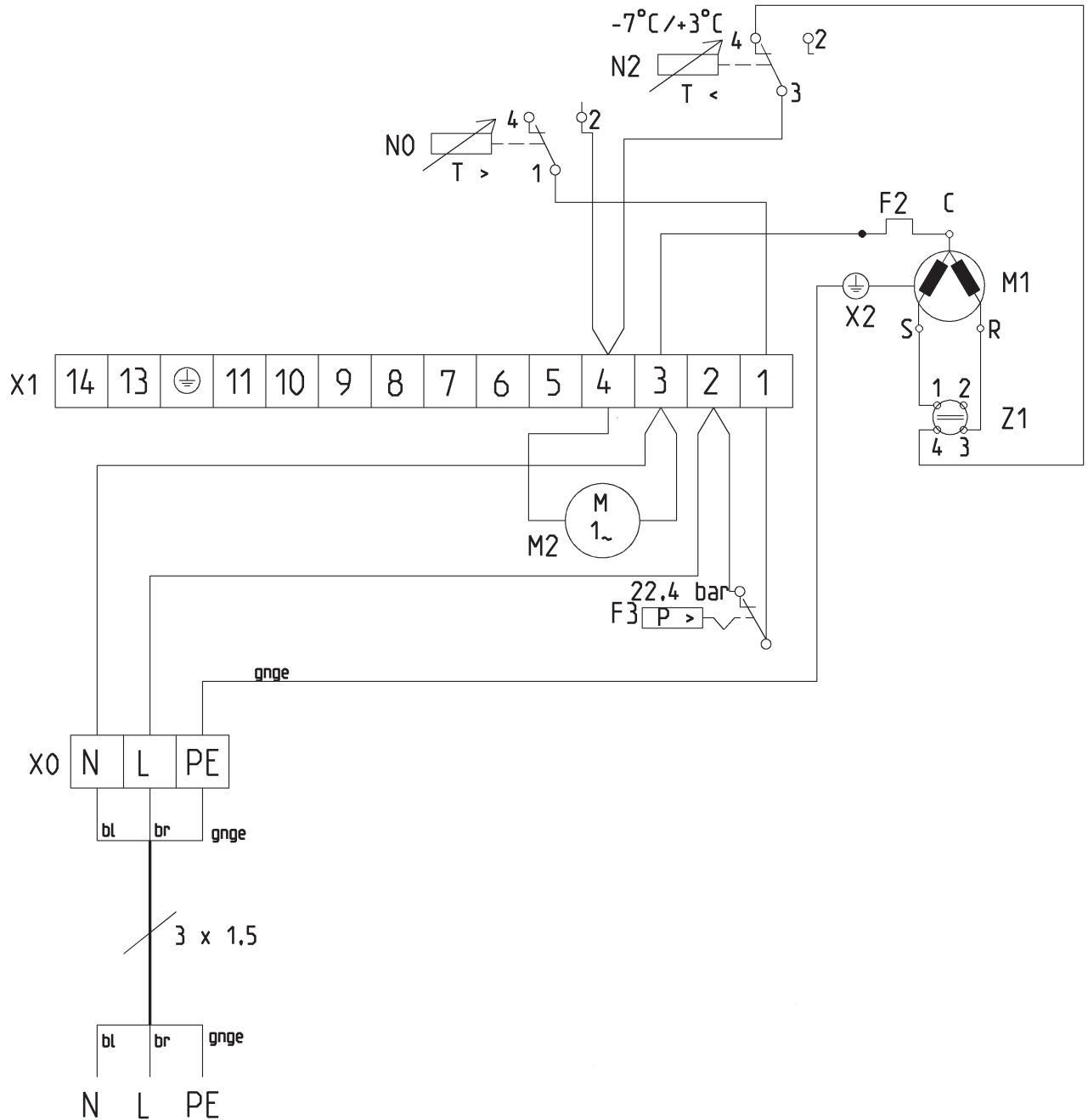

- F2 Compressor motor protection (Klixon)
- F3 High limit safety cut-out
- M1 Compressor
- M2 Fan
- N0 Heat pump control thermostat
- N2 Frost monitor
- X0 Power terminals
- X1 Heat pump terminals
- X2 Anode terminal earth
- Z1 Capacitor

Fig. 7

# Wiring diagram WWK 300 AH

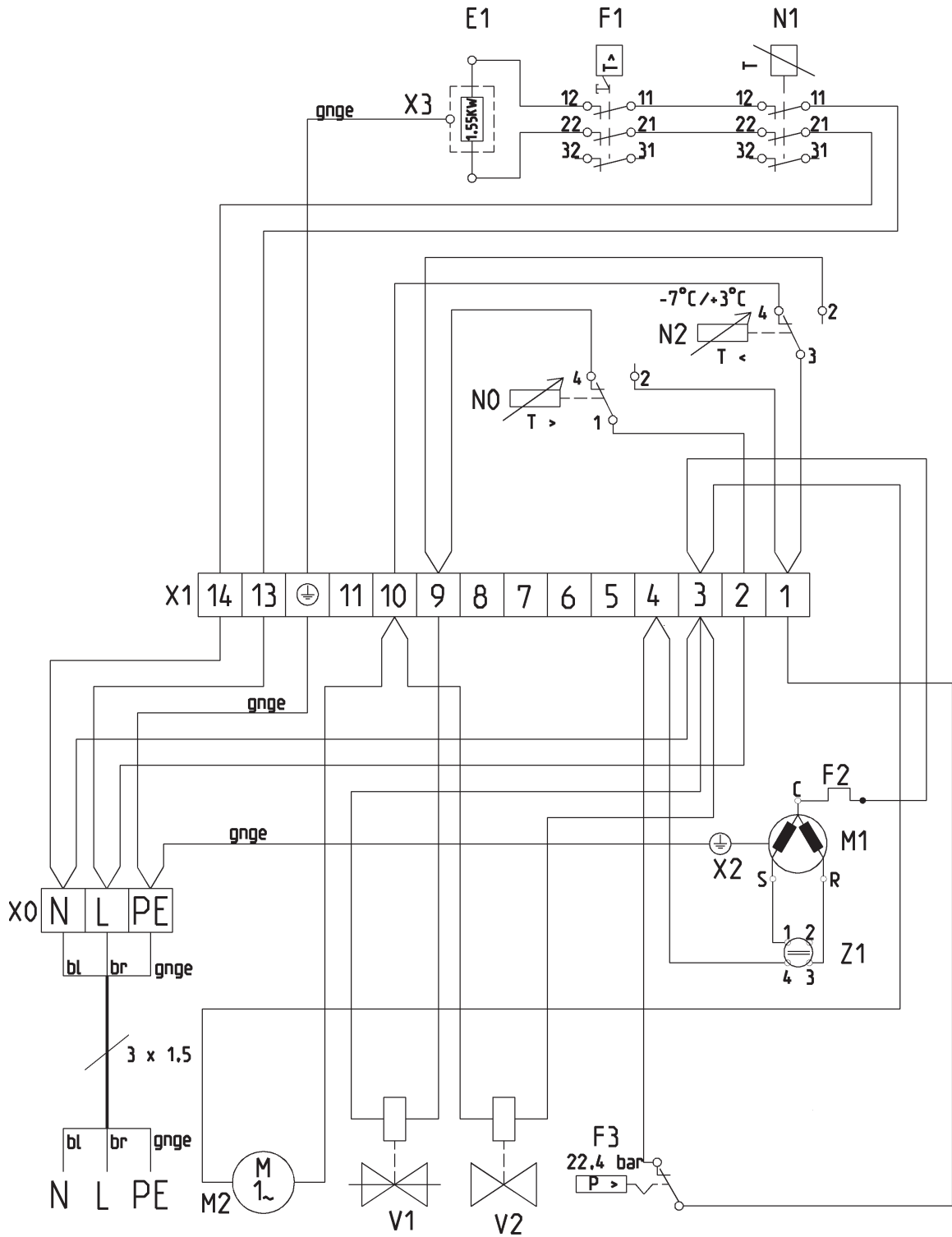

- |    |  |    |   |
|----|--|----|---|
| E1 | Electric booster heater                              | N1 | Control thermostat, electric booster heater |
| F1 | High limit safety cut-out<br>Electric booster heater | N2 | Frost monitor                               |
| F2 | Compressor motor protection (Klixon)                 | V1 | Solenoid valve                              |
| F3 | Safety pressure limiter                              | V2 | Solenoid valve                              |
|    | Heat pump  | X0 | Power terminals                             |
| M1 | Compressor   | X1 | Heat pump terminals                         |
| M2 | Fan  | X2 | Anode terminal earth                        |
| N0 | Heat pump control thermostat                         | X3 | Ground electric heating element             |
|    |  | Z1 | Capacitor                                   |

Fig. 8

## Wiring diagram WWK 300 AHP

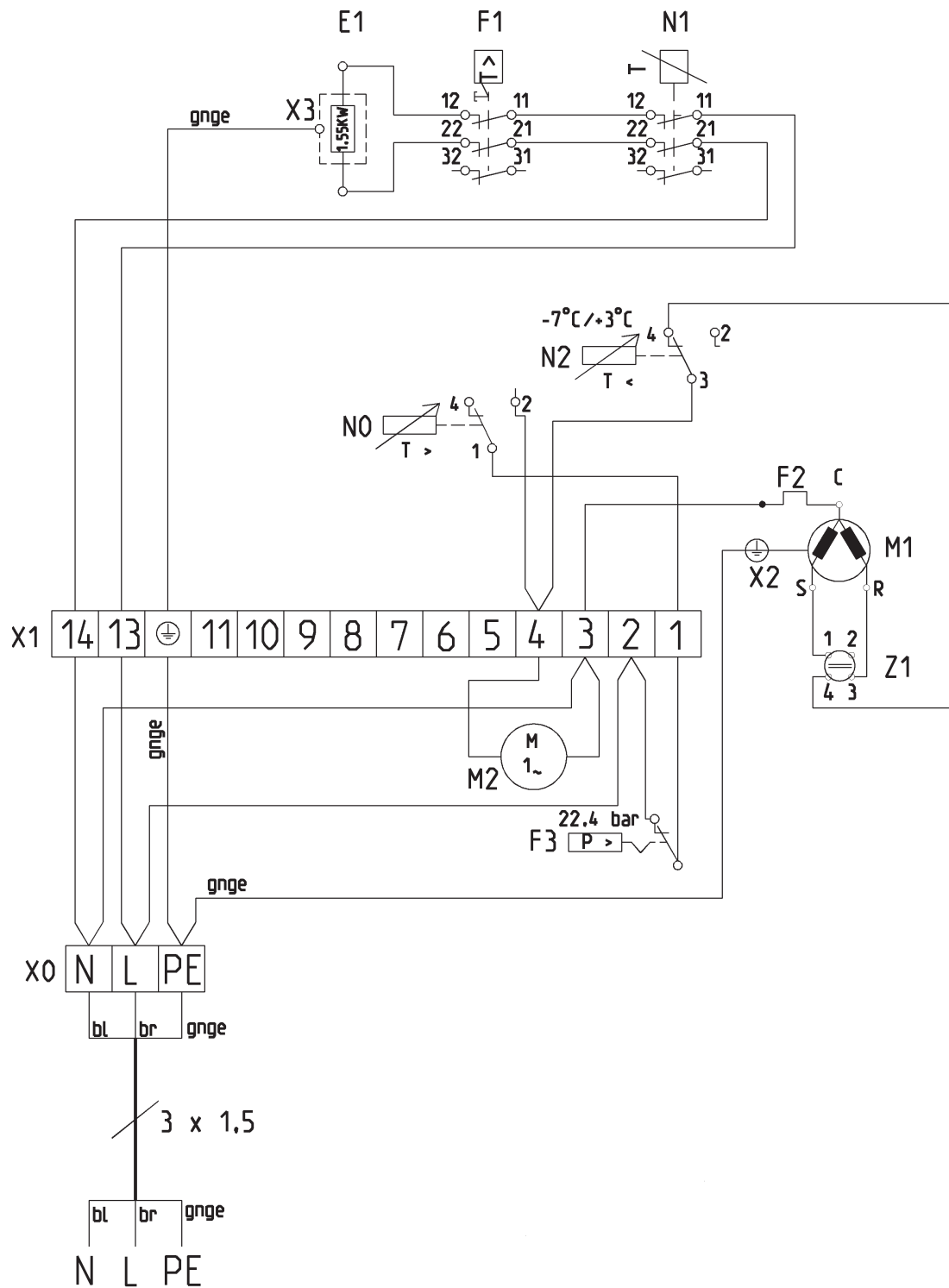

- |    |                                      |    |   |
|----|--------------------------------------|----|---|
| E1 | Electric booster heater              | N0 | Heat pump control thermostat                |
| F1 | High limit safety cut-out            | N1 | Control thermostat, electric booster heater |
|    | Electric booster heater              | N2 | Frost monitor                               |
| F2 | Compressor motor protection (Klixon) | X0 | Power terminals                             |
| F3 | Safety pressure limiter              | X1 | Heat pump terminals                         |
|    | Heat pump                            | X2 | Anode terminal earth                        |
| M1 | Compressor                           | X3 | Ground electric heating element             |
| M2 | Fan                                  | Z1 | Capacitor                                   |

Fig. 9

## 2.7 Specification

Type		WWK 300 A	WWK 300 AP	WWK 300 AH	WWK 300 AHP
Part no.		222422	227069	227070	227071
Version		with active defrost	with passive defrost	with active defrost and booster heater	with passive defrost and booster heater
Application limits for heat pump operation	°C	0 to + 42	6 to + 42	0 to + 42	+ 6 to + 42
DHW temperature	Heat pump	°C	+ 60	+ 60	+ 60
	Heating element	°C		+ 60	+ 60
Air flow rate	m <sup>3</sup> /h	550	550	550	550
Cylinder capacity	l	303	303	303	303
Refrigerant / filling weight	– / g	R 134a / 900	R 134a / 900	R 134a / 900	R 134a / 900
Dimensions H / Ø	mm	1875 / 660	1875 / 660	1875 / 660	1875 / 660
Height of unit when tilted	mm	1990	1990	1990	1990
Height of unit when tilted including packing	mm	2285	2285	2285	2285
Weight dry/wet	kg	125 / 428	125 / 428	130 / 432	130 / 432
Water connection	inch	R 1" (3/4" femal with adapter)	R 1" (3/4" femal with adapter)	R 1" (3/4" femal with adapter)	R 1" (3/4" femal with adapter)
Condensate connection	Inch	3/4"	3/4"	3/4"	3/4"
Condenser		Safety heat exchanger (tank wrap-around condenser)			
Maximum operating pressure, water side <sup>1)</sup>	hPa	600	600	600	600
Maximum positive pressure, refrigerant side	MPa	2.4	2.4	2.4	2.4

### Electrical specification

Voltage / Frequency	V / Hz	1/N/PE ~ 240 / 50			
Protection		IP 24	IP 24	IP 24	IP 24
Maximum power consumption <sup>2)</sup>	kW	0.7	0.7	2,25	2,25
Electrical protection	A	10 gL	10 gL	10 gL	10 gL
Rated current HP	A	2.5	2.5	2.5	2.5
Rated power consumption HP <sup>3)</sup>	kW	0.5	0.5	0.5	0.5
Power consumption, booster heater	kW			1.690	1.690
Heating output HP <sup>4)</sup>	kW	approx. 1.7	approx. 1.7	approx. 1.7	approx. 1.7
COP (t) <sup>4)</sup>		3.19	3.19	3.19	3.19

<sup>1)</sup> Cold water mains pressure must be limited to 500 kPa. Required P&T relief valve must open at 600 kPa.

<sup>2)</sup> Tamb = 42°C Twater = 60°C / 240V

<sup>3)</sup> Test point to DIN 8947 at 15 °C air temperature, 70 % rel. humidity and 45 °C water temperature.

<sup>4)</sup> Test point at 15 °C air temperature, 70 % rel. humidity, heating up water from 15 °C to 60 °C (according to EN 255 T3)

### Accessories

Type	Part no.	Description
PK 9	18 21 38	Condensate pump

## WARRANTY

For guarantees please refer to the respective terms and conditions of supply for your country.

The installation, electrical connection and first operation of this appliance should be carried out by a qualified installer.

The company does not accept liability for failure of any goods supplied which have not been installed and operated in accordance with the manufacturer's instructions.

## WARRANTY - Australia only

Stiebel Eltron (Aust) Pty Ltd warrants the domestic range of heat pump water heaters (WWK300 and WWK300 A) to be free from defects in material and workmanship under normal use and service in accordance with the following terms:

1. Repair or if necessary replace the water heater, or
2. Replace any component which falls within the warranty period as specified below (subject to the conditions and exclusions thereafter referred to)
  - 5 years for the cylinder and condenser
  - 2 years for the sealed refrigeration system, including compressor, evaporator, valves and associated pipe work.
  - 1 year for all other componentry (electrical)

The above shall not apply to such water heaters or part thereof which, in our opinion, have been subject to any accident, alteration, abuse or misuse or have suffered any damage by flood, fire or act of God, or if any repairs have been made or attempted to be made by any person or persons not approved by us. The warranties shall not extend to any loss suffered by, or resulting from, the non-operation of the water heater or part thereof.

We will not incur any obligation or liability whatsoever under the warranties for any damage or harm which may arise directly or indirectly as a result of the water heater being installed by other than registered qualified plumbers or being connected to a water or power supply not in accordance with the regulations of the relevant electric, water and health authorities.

The following items 1-5 are specifically excluded from the normal terms of warranty.

1. Damage as the result of transportation, removal, or storage.
2. Damage due to connection to incorrect water supply, incorrect installation or faulty valve.
3. Damage or faulty operation due to foreign matter in the water supply.
4. Damage or faulty operation due to the corrosive elements in the water supply and proper precautions not having been followed (eg, anode inspection & change)
5. Damage or faulty operation due to incorrect installation where the air flow, to and/or from the unit, is restricted or impeded

Notwithstanding anything contained herein, the units shall continue to be subject to any implied warranty provided by the Trade Practices Act 1974 (as amended) if and to the extent that the said Act is applicable and prevents the exclusion, restriction or modification of that warranty.

This free service will apply, in principle, to metropolitan and other accessible areas. If the unit is located in a remote area an extra service charge may be applicable due to travel.

Service costs by others are not covered by the Warranty and are at the user's expense. In the event of any claim being made under the warranty, it is the original purchaser's responsibility to provide evidence of purchase and date of purchase.

A nominal service charge may be made should the appliance be found to be in normal working condition and the problem located elsewhere.

STIEBEL ELTRON (AUST) PTY LTD

Unit 4, 109 Riverside Place

Morningside Q 4170

PH: 1800 153 351 - Fax: 07 3399 3344

## ENVIRONMENT AND RECYCLING

Please help us to protect the environment by disposing of the packaging in accordance with the national regulations for waste processing.

## Deutschland

STIEBEL ELTRON GmbH & Co. KG  
Dr.-Stiebel-Straße | D-37603 Holzminden  
Tel. 0 55 31 702 0 | Fax 0 55 31 702 480  
Email [info@stiebel-eltron.de](mailto:info@stiebel-eltron.de)  
[www.stiebel-eltron.de](http://www.stiebel-eltron.de)

## Verkauf

Tel. 0180 3 700705 | Fax 0180 3 702015 | [info-center@stiebel-eltron.com](mailto:info-center@stiebel-eltron.com)

## Kundendienst

Tel. 0180 3 702020 | Fax 0180 3 702025 | [kundendienst@stiebel-eltron.com](mailto:kundendienst@stiebel-eltron.com)

## Ersatzteilverkauf

Tel. 0180 3 702030 | Fax 0180 3 702035 | [ersatzteile@stiebel-eltron.com](mailto:ersatzteile@stiebel-eltron.com)

## Vertriebszentren

Tel. 0180 3 702010 | Fax 0180 3 702004

## Austria

STIEBEL ELTRON Ges.m.b.H.  
Eferdinger Str. 73 | A-4600 Wels  
Tel. 072 42-47367-0 | Fax 072 42-47367-42  
Email [info@stiebel-eltron.at](mailto:info@stiebel-eltron.at)  
[www.stiebel-eltron.at](http://www.stiebel-eltron.at)

## Belgium

STIEBEL ELTRON Sprl / Pvbva  
P/A Avenue du Port 104, 5 Etage  
B-1000 Bruxelles  
Tel. 02-4232222 | Fax 02-4232212  
Email [info@stiebel-eltron.be](mailto:info@stiebel-eltron.be)  
[www.stiebel-eltron.be](http://www.stiebel-eltron.be)

## Czech Republik

STIEBEL ELTRON spol. s r.o.  
K Hájům 946 | CZ-15500 Praha 5-Stodůlky  
Tel. 2-511 16111 | Fax 2-355 12122  
Email [info@stiebel-eltron.cz](mailto:info@stiebel-eltron.cz)  
[www.stiebel-eltron.cz](http://www.stiebel-eltron.cz)

## Denmark

PETTINAROLI A/S  
Madal Allé 21 | DK-5500 Middelfart  
Tel. 63 41 66 66 | Fax 63 41 66 60  
Email [info@pettinaroli.dk](mailto:info@pettinaroli.dk)  
[www.pettinaroli.dk](http://www.pettinaroli.dk)

## France

STIEBEL ELTRON S.A.S.  
7-9, rue des Selliers  
B.P. 85107 | F-57073 Metz-Cédex 3  
Tel. 03 87 74 38 88 | Fax 03 87 74 68 26  
Email [info@stiebel-eltron.fr](mailto:info@stiebel-eltron.fr)  
[www.stiebel-eltron.fr](http://www.stiebel-eltron.fr)

## Great Britain

Stiebel Eltron UK Ltd.  
Unit 12 Stadium Court  
Stadium Road  
Bromborough  
Wirral CH62 3QP  
Email: [info@stiebel-eltron.co.uk](mailto:info@stiebel-eltron.co.uk)  
[www.stiebel-eltron.co.uk](http://www.stiebel-eltron.co.uk)

## Hungary

STIEBEL ELTRON Kft.  
Pacsirtamező u. 41 | H-1036 Budapest  
Tel. 012 50-6055 | Fax 013 68-8097  
Email [info@stiebel-eltron.hu](mailto:info@stiebel-eltron.hu)  
[www.stiebel-eltron.hu](http://www.stiebel-eltron.hu)

## Netherlands

STIEBEL ELTRON Nederland B.V.  
Daviottenweg 36 | Postbus 2020  
NL-5202 CA 's-Hertogenbosch  
Tel. 073-6 23 00 00 | Fax 073-6 23 11 41  
Email [stiebel@stiebel-eltron.nl](mailto:stiebel@stiebel-eltron.nl)  
[www.stiebel-eltron.nl](http://www.stiebel-eltron.nl)

## Poland

STIEBEL ELTRON sp.z. o.o.  
ul. Instalatorów 9 | PL-02-237 Warszawa  
Tel. 022-8 46 48 20 | Fax 022-8 46 67 03  
Email [stiebel@stiebel-eltron.com.pl](mailto:stiebel@stiebel-eltron.com.pl)  
[www.stiebel-eltron.com.pl](http://www.stiebel-eltron.com.pl)

## Russia

STIEBEL ELTRON RUSSIA  
Urzhumskaya street, 4. | 129343 Moscow  
Tel. (495) 775 3889 | Fax (495) 775-3887  
Email [info@stiebel-eltron.ru](mailto:info@stiebel-eltron.ru)  
[www.stiebel-eltron.ru](http://www.stiebel-eltron.ru)

## Sweden

STIEBEL ELTRON AB  
Friggagatan 5 | SE-641 37 Katrineholm  
Tel. 0150-48 7900 | Fax 0150-48 7901  
Email [info@stiebel-eltron.se](mailto:info@stiebel-eltron.se)  
[www.stiebel-eltron.se](http://www.stiebel-eltron.se)

## Switzerland

STIEBEL ELTRON AG  
Netzbodenstr. 23c | CH-4133 Pratteln  
Tel. 061-8 16 93 33 | Fax 061-8 16 93 44  
Email [info@stiebel-eltron.ch](mailto:info@stiebel-eltron.ch)  
[www.stiebel-eltron.ch](http://www.stiebel-eltron.ch)

## Thailand

STIEBEL ELTRON Asia Ltd.  
469 Moo 2, Tambol Klong-Jik  
Ampur Bangpa-In | Ayutthaya 13160  
Tel. 035-22 00 88 | Fax 035-22 11 88  
Email [stiebel@loxinfo.co.th](mailto:stiebel@loxinfo.co.th)  
[www.stiebel-eltronasia.com](http://www.stiebel-eltronasia.com)

## United States of America

STIEBEL ELTRON Inc.  
17 West Street | West Hatfield MA 01088  
Tel. 413-247-3380 | Fax 413-247-3369  
Email [info@stiebel-eltron-usa.com](mailto:info@stiebel-eltron-usa.com)  
[www.stiebel-eltron-usa.com](http://www.stiebel-eltron-usa.com)

## Australia

STIEBEL ELTRON Australia Pty.Ltd.  
Unit 4/109 Riverside Place, Morningside, QLD, 4170  
Tel. 1800 153 351 | Fax 07 3399 3344  
Email [info@stiebel.com.au](mailto:info@stiebel.com.au)  
[www.stiebel.com.au](http://www.stiebel.com.au)